



COLGANTE
Technical Information

nomon
JEWELRY FOR HOME

COLGANTE

Technical Information

nomon
JEWELRY FOR HOME

TECHNICAL DRAWINGS

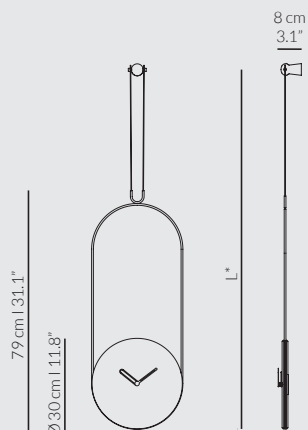

L*: Allows a maximum length of 4 meters /
Permite hasta un máximo de 4 metro de longitud

MATERIALS

PLATE/ PLATO

Solid walnut wood or marble Emperador, Sahara Noir or Calacatta Gold
/ Madera de nogal o mármol Emperador, Sahara Noir o Calacatta Gold.

HANDS / AGUJAS

Minute clock hand in solid walnut wood / Aguja minuterera en madera de nogal
Hour clock hand in polished brass or black finish / Aguja horaria en latón pulido o acabado negro

RING / ARO

Metal in brass or black finish / Metal acabado latón o negro

MECHANISM / MECANISMO

UTS German / UTS alemán

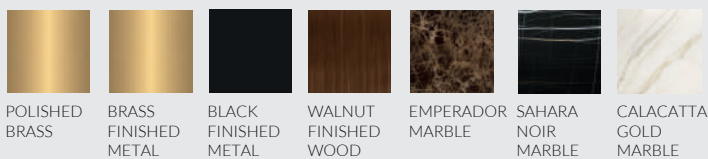

PACKAGING

Colgante in walnut weight / Peso colgante en nogal: 2.00 Kg | 2,00Kg
Colgante in walnut net weight / Peso neto colgante en nogal: 1.60 Kg | 1,60 Kg
Colgante in marble weight / Peso colgante en mármol: 4.50 Kg | 4,50Kg
Colgante in marble net weight / Peso neto colgante en mármol: 3.95 Kg | 3,95 Kg
Volumetric weight / Peso volumétrico: 5.40 Kg | 5,40 Kg
Dimensions / Dimensiones: 15.4" x 33.9" x 3.1" | 39cm x 86cm x 8cm

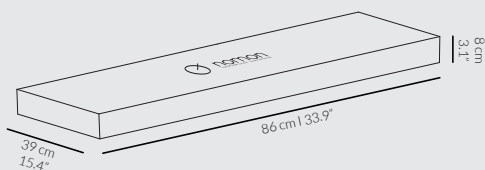

Assembly video / Video de montaje: <https://youtu.be/WuLx8uExdvg>

www.nomon.es