

PISA
Technical Information

nomon
JEWELRY FOR HOME

TECHNICAL DRAWINGS

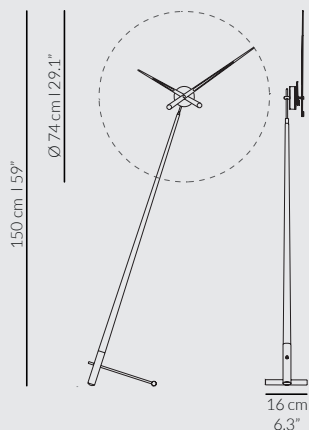

MATERIALS

BOX & BASE / CAJA Y BASE

Pisa L, N: Chromed brass / *Latón cromado*

Pisa G: Polished brass / *Latón pulido*

Pisa T: Graphite finished brass / *Latón acabado grafito*

HANDS & BODY / AGUJAS Y CUERPO

Pisa N, G, T: Walnut solid wood or wenge finished wood / *Madera de nogal natural o acabado wenge.*

Pisa L: Black, white or red lacquered walnut wood / *Madera de nogal lacada negro, blanco o rojo*

MECHANISM / MECANISMO

UTS German / *UTS alemán*

PISA L



CHROMED BRASS RED LACQUERED BLACK LACQUERED WHITE LACQUERED

PISA N

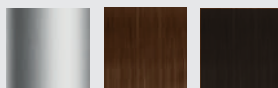

CHROMED BRASS WALNUT WOOD WENGE FINISHED WOOD

PISA G

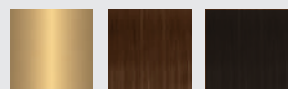

POLISHED BRASS WALNUT WOOD WENGE FINISHED WOOD

PISA T

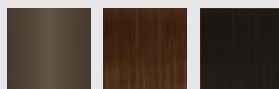

GRAPHITE FINISHED BRASS WALNUT WOOD WENGE FINISHED WOOD

PACKAGING

Weight / *Peso*: 2.80 Kg | 2,80 Kg

Net weight / *Peso neto*: 2.30 Kg | 2,30 Kg

Volumetric weight / *Peso volumétrica*: 2.80 Kg | 3,80 Kg

Dimensions / *Dimensiones*: 7.5" x 28" x 3.1" | 19cm x 125cm x 8cm

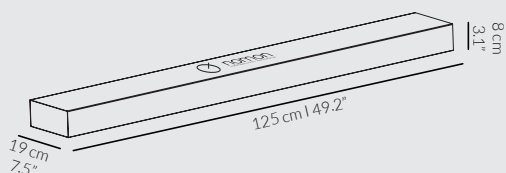

Assembly video / *Vídeo de montaje*: https://youtu.be/LsY_gIakXAA

www.nomon.es